

In this Issue:

- Product In Focus
- New Products
- Supersessions
- Getting Technical
- Staff Profile
- Advertising

## Bullseye September 2015

### Product In Focus - Air Springs

#### Features and Benefits

- Meets the highest international quality and environmental standards - ISO 9001, TS-16949 and ISO 14001
- Superior rubber and cord
- Engineered to meet OE specifications
- Corrosion resistance that withstands harsh operating conditions
- Excellent performance and quality through well developed product and manufacturing technology
- Convenient availability of range including Firestone brand to suit your application



#### Cross Section of Meritor Air Springs

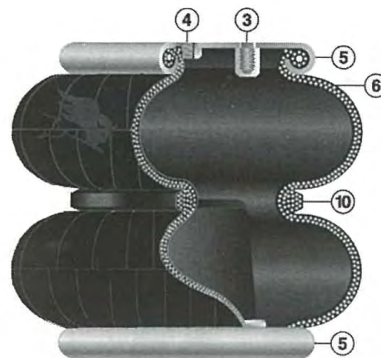
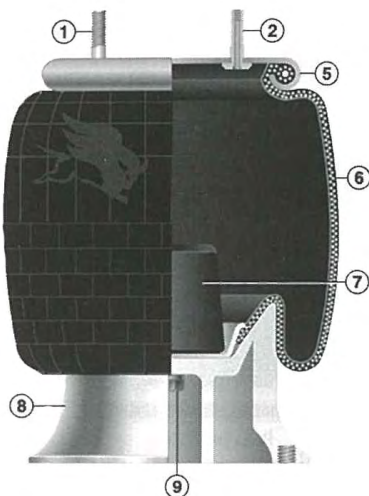

1. Mounting Stud
2. Combo Stud
3. Blind Nut
4. Air Fitting Hole
5. Bead Plate
6. Rubber Bellows
7. Internal Bumper - (optional)
8. Piston
9. Piston Bolt
10. Girdle Hoop



## Product In Focus - Air Springs

### Product Range - Top Selling Air Springs

Air Spring Part Number	OE Cross Ref	Rear	Application
21229214	21229214	•	ROR CS9
21221307	21221307	•	Holland (Please see ROR) Overslung U514 Overslung U524 & U534, Underslung E510, Overslung E520, E530, Kruger, R.F.S., ROR models
21222442	21222442	•	ROR Flexair - FL9000, FL9000H FL9000L, FL9000HL FLEXLITE XL9000
21227742	21227742	•	Ridestar RFS23T
21208082	21208082	•	Holland (Please see ROR) HO41 & H134 Underslung HO42 Overslung, Indair Including Axle Lift 21208082 2120 8082FS 4 Stud Airspring, FL11000L, Weweller FLO41, FL131
MLF7104	05.429.43.51.0 05.429.43.60.0	•	BPW Type 36 Complete Assembly
MLF7093	05.429.43.20.0	•	BPW Type 30 Complete Assembly (Plastic Piston)
MLF7177	05.429.43.20.0 05.429.40.93.1	•	BPW Type 36 Complete Assembly (Plastic Piston)
MLF7066	05.429.40.01.0	•	BPW Type 36 Service Assembly - Including Top Plate Only
MLF7045	05.429.40.91.0	•	BPW Type 30K Service Assembly - Including Top Plate Only
FS9622	K303-22	•	DAF Airglide Susp. 200, 400, 600 Series (for Outward Mounted Shock Absorbers) 9" Ride Height (large air fitting)
FS9144	90557155	•	Mack Neway Air Susp. AD252-11" Ride Height
FS9617	K303-18	•	DAF Airglide Susp. 200, 400, 600 Series (for Outward Mounted Shock Absorbers) 9" Ride Height (small air fitting), Kenworth Airglide Susp. 200, 400, 600 Series (With Shocks Mounted Outside Chassis Rail) With Outward Mounted Shock Absorbers & 9" Ride Height
FS9625	K303-25	•	DAF Airglide Susp. 200, 400, 600 Series (for Outward Mounted Shock Absorbers) 10.5" Ride Height (large air fitting)
FS9471	90557146 90557182	•	Iveco Eurostar LD5500 (520HP) With Neway AD246-10" FS9471 90557146 Air Suspension
FS7001	1102-0023	•	Freightliner Freightliner Link Cabmate Suspension



## New Products & Supersessions

### New Products

Part Number	Description	List Price **
8205983	Wheel Seal to suit Isuzu new drive axle wheel end	\$207.65
3100F8248	Centre Beam to suit Freightliner MFS axle	\$3218.18
E-UB8265-16	U Bolt Assy to suit U-Bolt Assembly, Square Bend, 7/8" - 14 Thd. x 5" Wide x 16" Long - Hendrickson	\$64.60
FS8614	Air Spring to suit Hendrickson Trailer OE# S26773	\$851.46

All parts displayed above will be available for immediate ordering. Lead times apply for the listed items.  
 Not all parts are available to Independent Customers.  
 Please contact Meritor Customer Service on (03) 8353 6050 for further information.

### Supersessions

Old Part Number	Description	New Part Number	List Price **
A3262A27A	Hub Cap 6 Hole 4P5	A3262X1506	\$61.37
A3262Z26A	Hub Cap 6 Hole 5P5	A3262Z1456	\$84.43
A3262B28A	Hub Cap 6 Hole 5P5	A3262Y1507	\$70.68

For a full list of supersessions, please [Click Here](#).

All parts displayed above will be available for immediate ordering. Lead times may apply for the listed items.  
 Not all parts are available to Independent Customers.  
 Please contact Meritor Customer Service on (03) 8353 6050 for further information.

\*\*All list prices are correct at time of printing and subject to change.

## Please contact your local OE Dealer for pricing information.



# Getting Technical - Air Spring Troubleshooting

## Air Springs - Replacement Indicator Guide



### Deformed Air Spring

#### Caused by:

- Improper storage
- Improper transport
- Improper handling

#### Solution:

- Storage adhered to iso 5285 no daylight, dry area
- Normal room temp
- Avoid improper handling and transport



### Damage of conical beads and nuts

#### Caused by:

- Improper mounted bead plate
- Pinching of the bellows with metal part

#### Solution:

- Keep conical beads clean & corrosion free
- Avoid driving without pressure in the air suspension

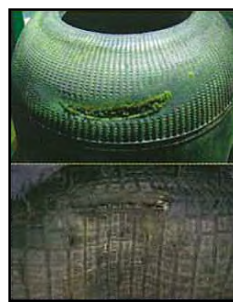

### Bellows rubs off at shoulder

#### Caused by:

- Bead plate diameter incorrect
- Bellows too long for application

#### Solution:

- Use original parts
- Avoid wrong cross references

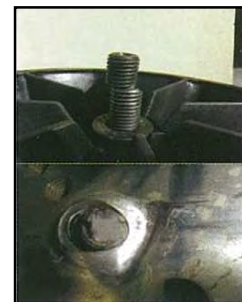

### Broken off thread bolts

#### Caused by:

- Excessive torque
- Use of oils or lubricants

#### Solution:

- Don't exceed recommended torque as per manual
- Avoid usage of oils and lubes



### Overextension

#### Caused by:

- Spring travel not restricted
- Incorrectly adjusted level control
- Air spring not suitable for application

#### Solution:

- Check the shock absorbers
- Check & adjust level the control valve
- Double check if the air spring fits the OE part number



### Abrasion

#### Caused by:

- Bellows contact with chassis parts
- Bellows contact with foreign bodies

#### Solution:

- Double check if the air spring fits the OE part number
- Check regularly & remove foreign objects stuck between bellows and piston



### Chemical contamination

#### Caused by:

- Usage of oils and lubes

#### Solution:

- Avoid usage of lubes or cleaners which contain mineral oils
- Check air springs on a regular basis



### Air spring bursting, broken piston

#### Caused by:

- Overload
- Exceeding the maximum allowable pressure

#### Solution:

- Never exceed the maximal allowed weight of the vehicle



## Getting Technical - Visual Search Additions to MPO

Enhancements to [www.meritorpartsonline.com](http://www.meritorpartsonline.com)

### Catalogue - (Please refer to Screen Shots)

- On Part Number Detail page, added 'Where-Used' option which displays other kits/assemblies containing the searched part number.
- Visual Search now includes clutch, gearing and suspension products.
- From left-hand navigation, facets are sorted by numerical sequence (not by number of hits).  
Example: Brake Diameter: 10.00, 12.00, 12.25, 14.50, etc.

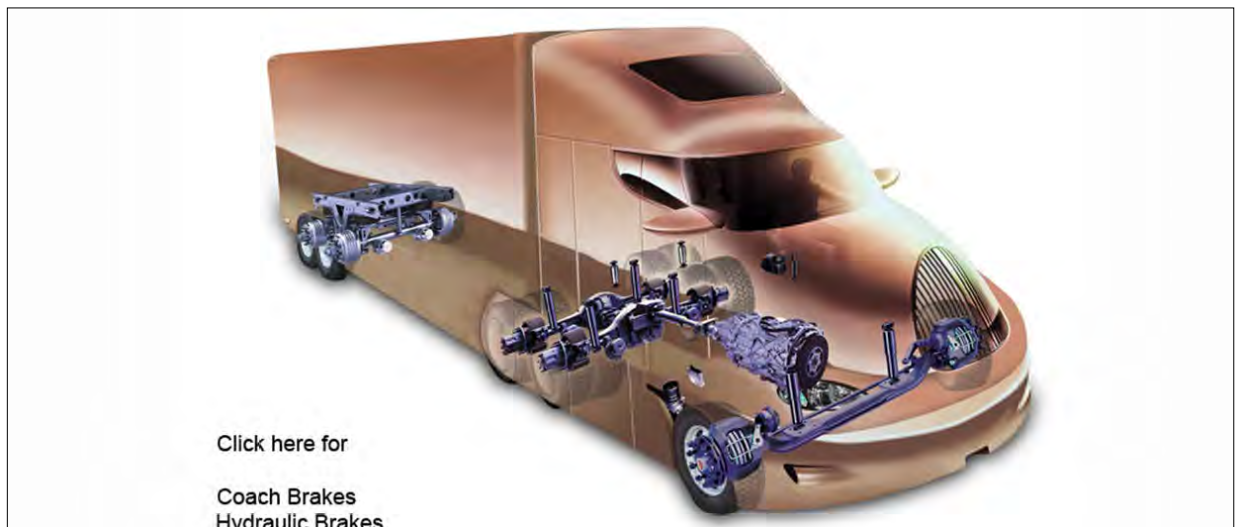
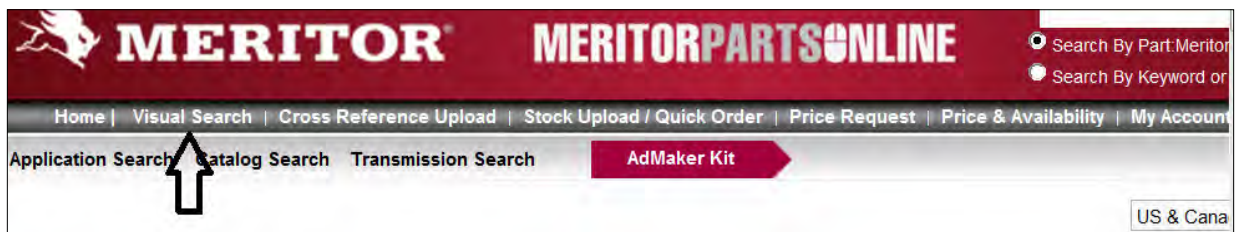
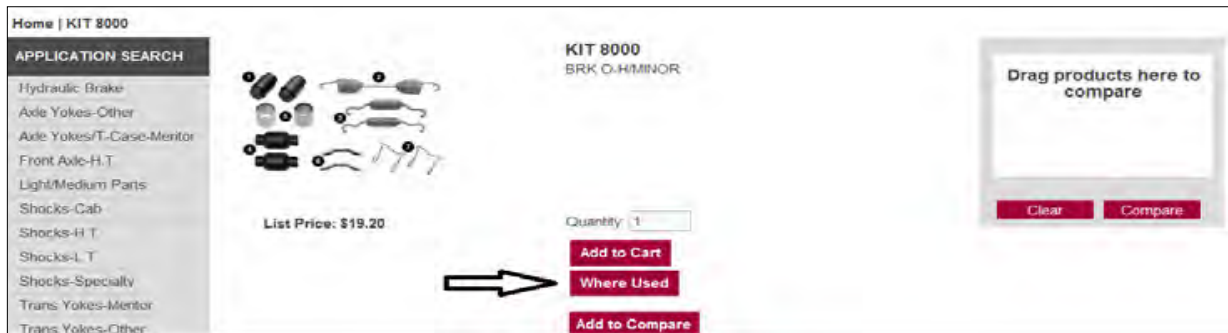



# Getting Technical - Visual Search Additions to MPO

Enhancements to [www.meritorpartsonline.com](http://www.meritorpartsonline.com) cont;

Home | Catalog Search | Brake Shoes | Lined Shoes

**Narrow your results by:**

**BRAND**

- Fras-Le (120)
- Meritor (480)
- Meritor AllFit (88)



**BRAKE DIAMETER**

- 10.00 in. (1)
- 12.00 in. (1)
- 12.25 in. (14)
- 14.50 in. (9)
- 15 in. (8)
- 15.00 in. (63)
- 15.13 in. (1)
- 16.50 in. (259)
- 18.00 in. (1)

**Lined Shoes**



Displaying products 1 - 12 of 688 < 1 - 58 >

S.No	Part No.	Description	Comments
1	A17 3222E2111	AY-SHOE & LNG	
2	A11 3222D1954	BRAKE SHOE	

Home | cp10\*

**Narrow your results by:**

**BRAND**

- Meritor (1)
- Meritor AllFit (3)

**BEARING DIAMETER**

- 0.938 in. (1)
- 1.000 in. (1)

**YOKE DIMENSION**

- 2.66 in. (1)





**CROSS LENGTH**

- 2.249 in. (2)

**Search Results**

Search for: "cp10\*", Number of results found: 4.

Displaying products 1 - 4 of 4

S.No	Part No.	Description	Comments
1	CP101X	CNTR PARTS KIT	 
2	CP101X BULK	CNTR PARTS KIT	
3	CP 103X	CTR PARTS KIT	

Clear Compare





## Employee Profile - Tej Mugathi

Role at Meritor: Customer Service Officer  
Year Joined: 2013

### What is your background in Customer Service?

I am an IT professional and this is my first job in Customer Service. I am excited to work in customer service as it gives me the opportunity to improve my communication and interpersonal skills.

### What are your main responsibilities?

I enter customer orders into the system, load and maintain pricing in the system by liaising with the Sales department. I raise requests to the finance team to setup respective customer accounts, pricing structures and change of address.

I am also involved in major projects (e.g.: Customer Transformation Project) from the customer service department and also liaise with IT department to perform testing, prepare flowcharts and documentation. I also consolidate customer orders, workbench and print shippers to deliver goods to the customer. I prepare process documents for the activities carried out in customer service team and communicate with external customers as required.

### How do you maintain excellence in customer service?

Understanding the customer service process helps me to address the internal and external customer's request in a timely manner. I am always looking for continuous improvement opportunities to enhance the service experience and to better support the customer.

### Why do you like working in customer service?

Working in customer service gives me the opportunity to communicate with a wide range of people. Understanding customer requirements and supporting their needs on time gives me great satisfaction.

### How does your work impact on the relationship between the customer and sales?

Entering customer orders accurately, maintaining pricing and keeping customer details up-to date as well as consolidating customer orders on time greatly supports the customer, which improves relationships and builds confidence between customer and sales.

### What are your interests and hobbies outside work?

I love spending time with my family and friends. My hobby is dancing, and I have recently joined in a dance group and performed at South Asian Food Festival, Werribee.



'...understanding customer requirements and supporting their needs in time gives me great satisfaction.'



## Advertising

Look out for our ad on Brake Shoe Kits in the next edition of Big Rigs!  
For more information on our comprehensive range of brake shoe kits, please contact your local Meritor Representative or call Customer Service on 03 8353 6050.

 **IDEAS DRIVING RESULTS**



**WILL YOUR SHOES PERFORM WHEN IT REALLY MATTERS?**

**Premature wear can be a result of inferior quality brake shoes. Insist on using genuine. Insist on Meritor.**

As the market leader in drum brakes, Meritor genuine KSMA Brake Shoe Kits provide premium performance and reliability, backed by the best support in the industry.

For more information on Meritor KSMA Brake Shoe Kits, visit [www.meritorpartsonline.com](http://www.meritorpartsonline.com), speak with your local OE dealer or contact Meritor Customer Service on 03 8353 6050.



**MERITOR**